

ThermalAir TA-5000A

An Evolution in Localized Temperature Test Systems



More Technology
More Control
More Temperature Capacity
More Energy Saving

Unique architecture of the ThermalAirTA-5000 creates unprecedented performance while saving up to 50% on electricity/energy/power!

Extremely Low Audible Noise refrigeration built-in DC Chiller for engineering lab environment

Active Temperature Control and Settable Ramp Rates for Temperature Profiling, Cycling, Thermal Shock and Testing directly at application on the Bench Top and Production Floor

Versatile Positioning Boom Arm & Stand compatible with test site pitches and hard to reach applications

Quick & Easy Interchangeable temperature head accessories [No hardware or tools required]

Performance Plus! - Productivity!

- Continuous Air Flow up to 20 SCFM @-80C/+225C
- -55C to +125C/ +125C to -55C less than 10 sec
- Ultra Stable DC Temperature Control
- Frost Free Operation / Built-in Air Dryer
- No LN2 or CO2 Required
- CFC Free / CE Mark

Flexibility

- Two user Touch Screen Displays on the Head & Front Panel
- USB & SSD Thermal File Management & Data Logging
- Easy Roll Around wheels for portability
- Plug-in Anywhere 200 to 250VAC, 50/60Hz [No configuration required]



Temperature Solutions **MPI Thermal** For The Future

A Division of MPI Corporation

Email: info@mpi-thermal.com · Web: www.mpi-thermal.com

TA-5000A ThermalAir Temperature conditioning System

Specifications

MPI Thermal ThermalAir TA-5000
A Division of MPI Corporation

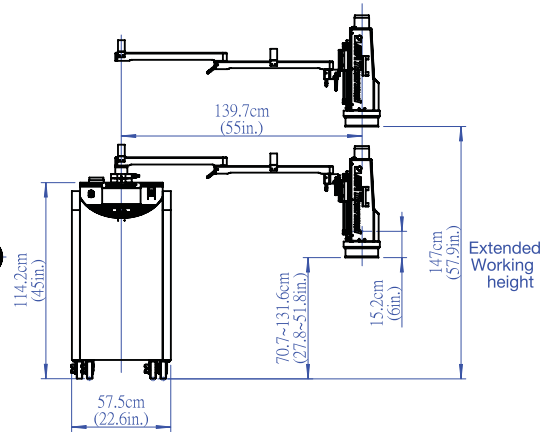
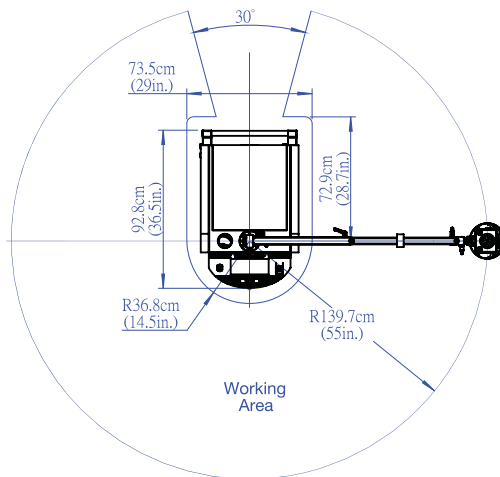

Full Inline Interface for all communication control Requirement

4 USB-Type A, 1 USB-Type B, HDMI, LAN, RS-232, T-Type, K-Type and RTD temperature sensors PLUS Auto Start Test & End of Test for automatic temperature cycling Hot-Cold-Amb. All this makes for simple control and service ability.

Specifications

Temperature Performance & Airflow Capacity

Temperature Range	-80°C to +225°C (50/60Hz same system)
Typical Temperature Transition Rate	-55°C to +125°C / +125°C to -55°C <10 sec
Temperature Accuracy	± 1.0°C (calibrated system)
Temperature Resolution	± 0.1°C
Temperature Air Output System	5 to 20 SCFM (2.4 l/s to 9.4 l/s) Continuous
Temperature Control Methods	Internal Air Temperature and Remote External Type T, K, RTD (TC Sensors)

Note: Systems Temperature Range is NOT Reduced@ 50Hz or @ High Air Flow Output Rates

Facility Requirements / Dimensions & Weights

Base Unit & System Weight	W=57.5cm(22.6in.),D=92.8cm(36.5in.),H=136.3cm(55.7in.) Un-packed : 265kg(584 lbs) / Packed : 395kg (870 lbs)
Portability	Static dissipative, four easy roll swivel caster wheels
Maximum Reach	139.7cm (55 in.)
Maximum & Minimum Heights	Standard:70.6~131.6cm(27.8~51.8in.)/Extended: 85.9~146.9cm(33.8~57.9in.)
Hi Temp Glass Cap Enclosures	7.0 inch I.D., 5.7 inch I.D.,5.5 inch I.D., Standard. Optional size available
Noise Level	<49 dBA average
Power	185 ~ 250VAC (220 Nominal),60 / 50 Hz, 30amp, 1 phase (185 ~250VAC, 60Hz ; 190 ~250VAC, 50Hz)

Compressed Air

Clean, Dry Air (CDA)	Filtered to 5µ particulate contamination Oil Content: < 0.10 ppm by weight and filtered to 0.01µ oil contaminants
Input Air Dewpoint	+10°C dewpoint or dryer @90PSI (6.2 BAR)
Input Air Pressure	90 to 110 PSIG (6.2 to 7.6 BAR)
Input Air Flow	15 to 30 SCFM (7.2 to 14.3 l/s) 25 SCFM nominal
Input Air Temperature	+15° to +25°C, +22°C nominal
Operating Temperature Environment	+15° to +28°C, +23°C nominal
Operating Humidity	0 to 60% RH, 45% nominal

Temperature Solutions **MPI Thermal** For The Future

A Division of MPI Corporation

Email: info@mpi-thermal.com · Web: www.mpi-thermal.com